



YANMAR

COMPACT WHEELED EXCAVATOR

B75W



Operating weight	7 400 - 8 000 kg
Dig depth	3,5 - 3,9 m
Engine power	55,4 kW (75 HP)
Bucket capacity	87 - 303 l
Lifting force (arm)	30 kN
Breakout force at bucket edge	38 kN
Reach	6,9 - 7,1 m

Compact urban excavator and landscaping specialist



HIGH PERFORMANCE

The B75W is very efficient and can perform tasks reserved for machines with higher weight. Thanks to its enormous lifting capacities and its precise hydraulic system, this 8 tons is capable of transporting and positioning particularly heavy loads on construction sites. This machine has great advantages for the logistics of materials and is therefore very interesting in construction and especially for the road construction. Equipped with a grab bucket, it allows in horticulture to catch and to load trucks.



ENGINE

Due to the latest EU Stage IIIB / EPA Tier 4 Final engine generation, the B75W works economically and is environmentally friendly. The B75W is also equipped with an Eco Mode.



SMART CONTROL

Smart Control System increases efficiency. The driver determines the optimum excavator power for different applications. This minimizes losses of energy or time.



EASY MAINTENANCE

The main organs of the machine are accessible very quickly and safely. The wide opening of the covers enables fast daily checks.





COMFORTABLE CABINE

The ergonomically-designed cab provides the operator with an exceptionally comfortable environment that enables a high degree of productivity. From the neatly arranged, clearly structured displays through the generously dimensioned storage compartments to the Soft-Touch interior or the optional Klimatronik – one thing is clear: the workplace is designed for the operator.



EASY TO USE

The B75W is fitted with various equipment which enable precise, comfortable and productive control of the machine: Smart control, Fingertip control and multi-function joysticks offer optimal handling to the operator for a productive workday.



RELIABILITY OF POWERLINE

The components of the powerline are highly efficient and reliable: no need to choose between power and compactness. Yanmar customers can make heavy tasks of construction site in narrow spaces.

POWERFUL AND EFFICIENCY

IMPROVED POWERLINE

THE ENGINE

The B75W is driven by a EU Stage IIIB / EPA Tier 4 Final engine. Exhaust gas after-treatment reduces emissions by up to 90%, including nitrogen oxides (NOx), hydrocarbons (HC) and fine dust. This is achieved through an improved combustion and injection system and a diesel oxidation catalyst (DOC). The engine does not need a particulate filter.

THE AUTOMATIC IDLING

The auto idling function (optional) saves fuel. If there is no activity, the engine switches to the idling position automatically - hence reducing the fuel consumption.

AUTOMATIC ENGINE SHUTDOWN

The switch-off time can be freely selected by the driver (optional).



HYDRAULICS SYSTEM WITH FOUR INDEPENDENT CIRCUITS

Thanks to the four independent hydraulic circuits, the B75W wheel excavator increases its capacity with attachment tools. The driver can operate a tilt rotator with a hydraulic quick-hitch system and a hydraulically-driven tool, such as a sorting grab, asphalt cutter or cutting unit, for example. The control circuits can be operated at the same time, they do not influence each other.

STABILITY

The laterally installed engine stabilizes the machine, especially with a fully extended, offset boom.

ARTICULATED JOINT

With wide angle of articulation allows for working closely along walls.

CYLINDERS

+ All cylinders have end position damping for low-vibration working.



PERFORMANCE

SPEED

A quick change of construction site or location is possible with speeds of up to 30 km/h. Non-productive transport times are reduced to a minimum.

FURTHER ADVANTAGES

- + Hydrostatic travel drive, independent of the working hydraulics – also functions as an additional brake system
- + Automatic drive, additional accelerator pedal for delicate machine movements.



UNDERCARRIAGE

The undercarriage combines high terrain mobility with drive power. It can be configured as exactly required due to a wide range of equipment variants.

PENDULUM AXLE

Due to the pendulum axle with a pendulum angle of 14°, the wheeled excavator is absolutely stable even on uneven ground.

HYDROSTATIC TRAVEL DRIVE

- + Independent from working hydraulics.
- + Also functions as an additional brake system.

FURTHER ADVANTAGES

- + Articulated joint with wide angle of articulation allows for working closely along walls.



EASE OF USE

SMART CONTROL

Smart Control is an operating system for compact wheel excavators with new engines in the EU Stage IIIB / EPA Tier 4 Final class. It has never been easier to match a construction machine precisely to the driver and application. Numerous controls have also been redesigned and rearranged for quicker operation and improved machine monitoring.

What this means for you:

- + Intuitive operation that is easy to set for each individual driver
- + 1st, 2nd and 3rd Electric proportional hydraulic control circuit for operating work attachments
- + New display design to enable easy machine monitoring
- + Keypad with extra-large keys for easy operation



PRECISE FINGERTIP CONTROL

The fingertip control allows the operator to regulate the oil flow with real precision, all the way from « zero » to « full ».

The electrical proportional activation of hydraulic functions is simple thanks to a thumbwheel on the joystick. A lot of attention has been paid to an outstanding ergonomomy to improve operator comfort.

EXEMPLARY MACHINE CONTROL

+ Hydraulic control circuits

Allow fast operation. The flow rate of the control circuits is also adjusted proportionally during continuous operation via a bar chart according to use and attachment tool.

+ Eco mode is switched on with just the touch of a button

+ Air conditioning control

Heating and defrosting can be adjusted exactly to the required conditions, automatic air conditioning is optional.



OPERATOR STATION

Designed with driver comfort and productivity in mind, the cabs feature noise and vibration damping and are ROPS/FOPS- approved.



DISPLAY AND INSTRUMENTS

For a clearer overview and greater convenience – work functions and machine information can be examined at a central position in a glance. The data display appears in a tiled look like a smart phone.

The anti-reflective screen with a 7" diagonal is very clearly arranged and is also used as a monitor for the standard reversing camera.

THE KEYPAD

Extra-wide pressure surface make safe operation easy, even when wearing gloves. The optional immobilizer can be operated.

FURTHER ADVANTAGES

+ Additional mirrors for improved visibility.



MAINTENANCE

EASY ACCESS

A servicebar with the central electrics is integrated in the service compartment: Hence, all relays and fuses are easy to access from the ground. The flap can be opened without tools.

For easier ascent, the ladder in the service flap is extended towards the ground. The flap is provided with rubber buffers, it lies gently on the extended ladder, the materials is conserved.

There are no main hydraulic components mounted under the cab. Tilting of the cab is not required – but possible if necessary.



DIAGNOSTIC PLUG

The diagnostic plug for engine and machine data speeds up maintenance and service through better communication between man and machine.

«Can bus» data are shown on the display.



Refueling with a jerry can.

TAILORED FOR YOUR JOB

STEERING

Can be equipped with two-wheels or all-wheel steering

UNDERCARRIAGE OPTIONS

Stabilizers

Support plate

Front dozer blade

Narrow plate combined with single tires (1990 mm)

TIRE OPTIONS

Low-pressure tires and twin or wide tires are available.

LEVELING

The optional float function of the dozer blade makes leveling of the ground, the filling processes or cleaning of the construction site easier.

BOOM OPTIONS

Yanmar provides the right boom system for different applications. The excavation work is carried out in an optimum manner, quickly achieving the required result.

TPA boom, with dipperstick 1 650 mm

TPA boom, with dipperstick 1 950 mm

Circular boom, with dipperstick 1 600 mm

STANDARD ARTICULATED BOOM

The standard TPA booms are suitable for high-performance digging work, transport and precise positioning of heavy loads – the action radius is designed for the greatest possible working range.

CIRCULAR BOOM

The circular boom, with its small working envelope, is suitable for construction sites where space is limited.

LONG DIPPERSTICK

The B75W wheel excavator achieves a greater reach on the articulated boom due to an extended dipperstick with 1950 mm.

THE ATTACHMENT TOOLS

Excellent versatility thanks to numerous options and attachment tools. Tested and proven in use:

- + Light-material bucket
- + Standard bucket
- + Ditch-cleaning bucket
- + Swing bucket
- + Hydraulic cutting units
- + Ripper tooth
- + Adapter for rock beaker
- + Load hook
- + Screw-on load hook
- + Mechanical quick-hitch system
- + Hydraulic quick-hitch system
- + Pallet fork



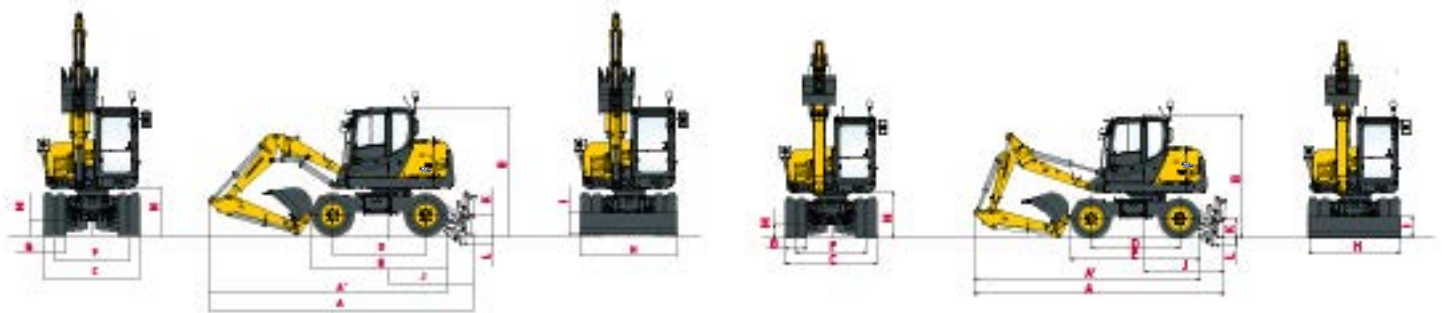

	TPA Boom	Circular Boom		TPA Boom	Circular Boom
A Overall length	6 030 mm	5 990 mm	H Overall blade width	1 990 mm	1 990 mm
A' Overall length with blade at the back	5 430 mm	5 410 mm	I Overall blade height	452 mm	452 mm
B Overall height	2 935 mm	2 935 mm	J Blade distance	1 915 mm	1 915 mm
C Overall width	2 190 mm	2 190 mm	K Max. blade height above the ground	465 mm	465 mm
D Wheel base	2 125 mm	2 125 mm	L Max. blade depth	200 mm	200 mm
E Undercarriage length	3 095 mm	3 095 mm	M Minimum ground clearance	325 mm	325 mm
F Lane	1 682 mm	1 682 mm	N Ground clearance under counterweight	1 100 mm	1 100 mm
G Tire width	508 mm	508 mm			

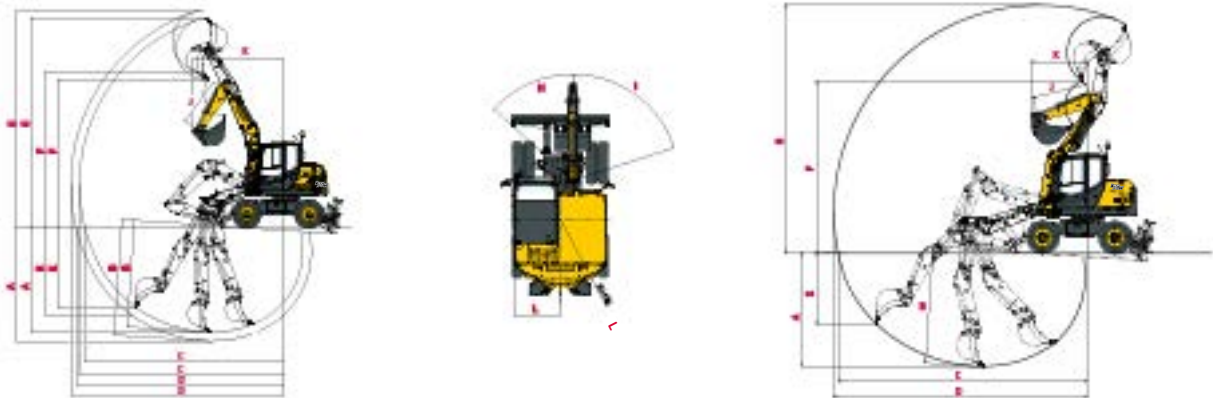

	TPA Boom	Circular Boom		TPA Boom	Circular Boom
A Max. digging depth - Blade lifted	3 580/*3 880 mm	3 320 mm	G Max. cutting height	7 130/*7 400 mm	7 290 mm
B Max. digging depth - Blade lowered	3 650/*3 960 mm	3 430 mm	H Boom swinging base to left	48°	48°
C Max. digging reach on ground	6 810/*7 100 mm	7 290 mm	I Boom swinging base to right	72°	72°
D Max. digging reach	7 120/*7 300 mm	7 420 mm	J Arm length	1 650/*1 950 mm	1 600 mm
E Max vertical wall	2 740/*2 990 mm	2 070 mm	K Front turning radius	3 130 mm	1 610 mm
F Max. dumping height	5 060/*5 050 mm	5 050 mm	L Rear turning radius	1 480 mm	1 480 mm

* Dipperstick 1 950 mm

DIMENSIONS

Fig. 1 :
Excavation within the entire width of the machine

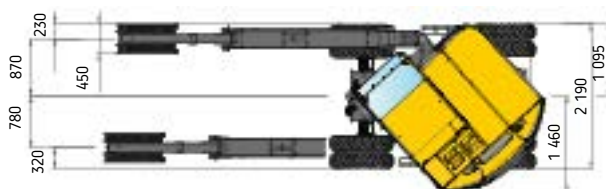
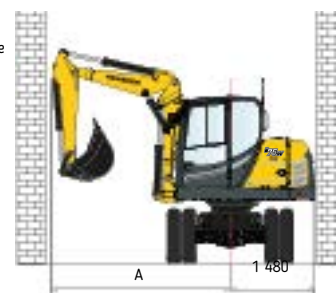

Fig. 2 :
Working envelope



LIFTING FORCE



Blade down



Blade up



Tipping load,
rating over front



Tipping load,
rating over side 90°

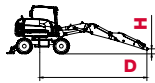

Articulated boom with dipperstick 1650 mm

		Articulated boom with dipperstick 1650 mm									
		d									
		3 m		4 m		5 m		6 m		7 m	
H	3,0 m										
		-	-	1,40	1,33	0,87	1,07	0,95	0,87	-	-
		-	-	1,40	1,36	0,86	1,07	0,68	0,80	-	-
		1,58	2,34	1,26	1,47	0,99	1,06	0,92	0,65	-	-
		1,4	2,17	1,25	1,41	0,98	1,01	0,63	0,62	-	-
0,0 m	2,41	1,91	1,53	1,26	1,00	0,90	0,88	0,81	-	-	
	1,69	1,76	1,14	1,18	0,82	0,86	0,76	0,78	-	-	
- 1,0 m	2,67	1,95	1,72	1,31	1,07	1,11	-	-	-	-	
	1,72	1,78	1,16	1,20	0,83	0,99	-	-	-	-	

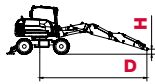

Articulated boom with dipperstick 1950 m, additional counterweight

		Articulated boom with dipperstick 1950 m, additional counterweight									
		d									
		3 m		4 m		5 m		6 m		6,3 m	
H	3,0 m										
		-	-	1,00	0,87	0,70	0,70	0,88	0,86	-	-
		-	-	0,98	0,85	0,70	0,70	0,87	0,86	-	-
		2,26	2,17	0,90	0,87	0,87	0,86	0,88	0,89	0,83	0,84
		2,26	2,15	0,88	0,87	0,87	0,86	0,88	0,86	0,83	0,79
0,0 m	2,37	2,27	1,50	1,40	1,17	1,12	0,87	0,87	-	-	
	2,31	2,17	1,47	1,40	1,16	1,12	0,87	0,85	-	-	
- 1,0 m	2,64	2,41	1,72	1,60	1,21	1,19	-	-	-	-	
	2,52	2,25	1,68	1,52	1,20	1,11	-	-	-	-	

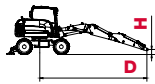

Circular boom with additional counterweight

		Circular boom with additional counterweight									
		d									
		3 m		4 m		5 m		6 m		7 m	
H	3,0 m										
		3	2,46	1,78	1,35	1,27	0,97	0,73	0,59	-	-
		1,91	2,42	1,26	1,32	0,88	0,93	0,57	0,59	-	-
		2,14	1,61	1,87	1,24	1,33	0,92	0,89	0,64	-	-
		2,05	1,58	1,44	1,22	0,83	0,87	0,57	0,62	-	-
0,0 m	3,05	1,76	1,89	1,19	1,74	0,83	0,78	0,70	-	-	
	1,6	1,67	1,07	1,16	0,75	0,81	0,62	0,69	-	-	
- 1,0 m	2,7	1,74	1,63	1,16	1,24	0,96	-	-	-	-	
	1,58	1,69	1,03	1,10	0,86	0,91	-	-	-	-	

All values specified in tons (t) were determined in compliance with ISO 10567 and include a stability factor of 1,33 or 87% of the hydraulic lifting capacity. All values were determined with quick-mount hitch but without bucket. In case of mounted-on work attachments, the deadweights of the work attachments must be deducted from the permissible payloads.



SPECIFICATIONS

WEIGHT

Operating weight (TPA boom, circular boom) acc. to ISO 6016	7 400 - 7 600 kg
Total length, travel position (TPA boom)	5 210 mm
Total height, travel position (TPA boom)	3 595 mm
Transport dimensions (TPA boom L x H)	5 710 x 2 920 mm
Total width (twin tires)	2 190 mm
Total height (top of cab)	2 935 mm
Tread width	1 682 mm
Wheelbase	2 125 mm
Ground clearance below cardan shaft	420 mm
Turning radius (front-axle steering / 4-wheel steering)	6 700 / 5 700 mm
Uppercarriage tailswing	1 480 mm
Uppercarriage frontswing	2 750 mm
Working envelope 180° (circular boom)	4 200 mm
Working envelope 360° (circular boom)	5 500 mm

ENGINE

Manufacturer, model.	Deutz, TCD 2.9 L4
Type.	4-cylinder Turbo diesel engine with intercooler - EU Stage IIIB / TIER 4 final
Combustion.	4-stroke cycle, Common Rail injection
Displacement.	2 900 cm ³
Net power rating at 2000 rpm (ISO 9249).	55,4 kW (75 HP)
Torque.	300 Nm at 1 600 rpm
Cooling system.	Water

HYDRAULIC SYSTEM

Travel hydraulics: closed circuit, independent from working hydraulics.	
Pump capacity, max.	88 l/min
Working pressure, max.	420 bar
Working hydraulics: Axial-piston variable displacement pump with load sensing, coupled with a load independent flow sharing (LUDV). Simultaneous, independent control of all movements. Sensitive maneuvers irrespective of loads.	
Max. pump capacity.	138 l/min
Working pressure, max.	250 bar
The thermostatically controlled oil circuit ensures that the oil temperature is promptly reached and avoids overheating. Return filter installed in oil tank allows for eco-friendly replacement of filter elements.	
Gear pump for steering and brake.	
Pump capacity, max.	35 l/min
Working pressure, max.	175 bar
Control circuit for work attachments, proportionally operated.	
Pump capacity, adjustable.	0 - 90 l/min
Working pressure, max.	250 bar
Two servo-assisted joystick controls (ISO) for excavator operations.	

TRANSMISSION

Hydrostatic drive with 2-stage planetary gear and axial piston fixed displacement motor, also acts as wear-resistant brake. In addition, spring-loaded multi-disc brake acting as parking brake			
2 speed ranges:	“Low”	0-6 km/h	4 speed ranges (high-speed version optional):
	“High”	0-20 km/h	
	“Low”	0-6 / 0-17 km/h	
	“High”	0-11 / 0-30 km	

EQUIPMENT

[STANDARD EQUIPMENT]

CABINE

Spacious, sound-insulated full-vision steel cab (ROPS certified). Sliding window in cab door.
Safety glass windows, thermo windows tinted in green. Skylight thermos window, bronze tinted.
Panoramic rear window.
Front window supported by pneumatic springs, lockable for ventilation and slidable under cab roof. Windshield washer system. Storage compartment.
Preparation for radio installation. Left-hand outside rear-view mirror.
Cab heating with windshield defroster through coolant heat exchanger with continuous fan. Fresh air and recirculating air filters.
Rearview camera.
Operator's seat MSG 85 (comfort version), hydraulic damping, extra-high backrest, tilt-adjustable armrests, longitudinal-horizontal suspension, mechanical lumbar support. Lap belt.
Instrument panel on the right hand side of the operator's seat with visual & acoustic warning device, hour-meter and safety module.
Working floodlights Halogen H-3.
Sound power level (LWA) 99 dB (A).
Sound pressure level (LpA) 77 dB (A).
Sound level values measured in compliance with Directive 2000/14/EC and EN474.
Effective values of acceleration for whole body less than 0.5 m/s ² .
Effective values of acceleration for hand-arm less than 2.5 m/s ² .
Vibration values in compliance with Directive 2006/42/EC and EN474.

AXLES

Front : Oscillating planetary drive axle. Oscillating angle	14°
Rear: Rigid planetary drive axle.	

STEERING

Fully hydraulically controlled front axle with integrated steering cylinder.	
Max. steering angle	35°

SWING SYSTEM

Hydrostatic drive with 2-stage planetary gear and axial piston fixed displacement motor, also acts as wear-resistant brake. In addition, automatically controlled spring-loaded multi-disc brake acting as parking brake.	
Swing speed	0-10 rpm

KNICKMATIK®

Lateral parallel adjustment of boom arrangement at full dig depth.	
Angle of articulation / lateral adjustment left	48° / 780 mm
Angle of articulation / lateral adjustment right	72° / 880 mm

ELECTRICAL SYSTEM

Nominal voltage	12V
Battery	12V / 105 Ah
Generator	14V / 95 Ah
Starter	12V / 2,6 kW

FLUID CAPACITIES

Fuel tank	150 l
Hydraulic system (incl. Tank 60 l)	180 l

BRAKES

Service brake: Hydraulic pump accumulator two-circuit brake, acting on oil-immersed multi-disc brakes of front and rear axle.
Excavator brake: Acting on front and rear axle due to lockable service brake.
Auxiliary brake: Hydrostatic travel drive in closed circuit acting as non-wearing auxiliary brake.
Parking brake: Hydraulic spring-loaded brake, electrically actuated.

TIRES

Standard 8.25-20, 12 PR twin tires.

MAINTENANCE FREQUENCY

Change engine oil and filter:	500h or minimum once a year.
Change fuel filter:	1 000h or minimum once a year.
Change hydraulic oil:	check at 100 + 500 h; every 1 000h or minimum every 2 years.
Change hydraulic oil filter:	first after 100h, then follow the instructions at display.
Change cooling fluid:	if needed or minimum every 2 years.

[OPTIONAL EQUIPMENT]

BOOM OPTIONS

TPA boom, with dipperstick 1950 mm | TPA boom, with dipperstick 1650 mm | Circular boom, with dipperstick 1650 mm.

TIRES

365/70 R 18 MPT E-70 Conti (single tires, vehicle width 1985 mm) | 500/45-20 (single wide tires).

HYDRAULIC SYSTEM

Open return | Hydraulic installation for quick-hitch system | Biodegradable hydraulic oil / ester-based HLP 68 (Panolin) | Fingertip control incl. second additional control circuit on left joystick | Fingertip control incl. third additional control circuit on left joystick.

OPERATOR'S STAND

Operator's seat MSG 95 (premium version), air damping, extra-high backrest and tilt-adjustable armrests, longitudinalhorizontal suspension, seat and backrest heating, pneumatic lumbar support | Klimatronic | Thermoelectric cooler box.

ENGINE

Diesel particulate filter (DPF) | Automatic idling system.

CABINE

Lighting package : 1 double beam working floodlight - cab-mounted rear center, 1 working floodlight cab-mounted - front right | FOPS - skylight guard | Sliding window on right-hand side | Yellow beacon | Radio set installation kit.

OPTIONAL SUPPORT / DOZER SYSTEMS

Rear support blade, 2200 mm wide (with twin and wide tires) | Rear support blade, 1990 mm wide (with single tires) | Outrigger plates, flat, oscillating | Outrigger plates, rubber-coated, oscillating | Front dozer blade, 2200 mm wide.

OTHER OPTIONAL EQUIPMENT

Four-wheels steering switchable from four-wheel to crab steering | Electrical refueling pump | Quick-hitch system, mechanical, type MS08 | Quick hitch system, hydraulic, type HS08 | Anti-theft device (immobiliser) | Engine-independent diesel heater with fresh air circulation and timer | Additional rear weight, 107 kg | Rear view camera | Additional tool box | Steering change-over in case of blade operation | Further optional equipment available on request.

[WORK ATTACHMENTS]

BUCKETS

Bucket, QAS, light material, without teeth 300 mm wide, capacity 87 l | Bucket, QAS, light material, without teeth 400 mm wide, capacity 127 l | Bucket, QAS, light material, without teeth 600 mm wide, capacity 212 l | Bucket, QAS 300 mm wide, capacity 87 l | Bucket, QAS 400 mm wide, capacity 127 l | Bucket, QAS 500 mm wide, capacity 169 l | Bucket, QAS 600 mm wide, capacity 212 l | Bucket, QAS 800 mm wide, capacity 303 l | Ditch-cleaning bucket, QAS 1,250 mm wide, capacity 251 l | Swing bucket, QAS 1,250 mm wide, capacity 220 l.

OTHER WORK ATTACHMENTS

Ripper tooth / QAS (1 tooth) | Auger | Hydraulic hammer | Quick-hitch adapter for hydraulic hammer | Bolt-on load hook for bucket rod | Further work attachments available on request.



YANMAR



Yanmar Construction Equipment Europe
25, rue de la Tambourine, 52100 SAINT-DIZIER
France

ycee-contact@yanmar.com

www.yanmarconstruction.eu

Printed in France - Materials and specifications are subject to change from the manufacturer without notice - Please contact your local Yanmar Construction Equipment Europe dealer for further information.

GB_B75W_0218